

IMT products are:

- Maintenance free
- Safety
- Environmental friendly

ILED® Aquarius Repeater Light

Main Characteristics

Approx 100,000 'maintenance free' operational hours.
Luminaire is sealed for life
Shock and vibration resistant
According to ICAO Annex 14, CAA CAP 437 and IMO Modu code 2001

Specification/Technical Data

Housing	: Stainless Steel 316L (AISI)
Lens	: Toughned Soda Lime Glass
LED Colour	: Red
Ingress Protection	: IP66
Voltage Range	: 24Vdc
Power	: 10W
Burning position	: Base Down
(Re)ignition	: Instant
Ambient Temperature	: -40°C...to +55°C
Termination	: Standard – Ex e junction box c/w 3x<20 entries, terminals suitable for Max 4 mm ² .
Flash Frequency	: 1Hz or 2Hz

Certification details

Atex Classification	: Group II, Category 2, Gas and Dust
Area Classification	: Category 2 (Zone 1 and 21)
Certificate	: KEMA 08ATEX0158X
Marking	: EXII 2 G Ex e mb II T4 EXII 2 D Ex tD A21 IP66 T100°C
Restriction	: Only in use with IMT system

Options

Mounting Brackets	: On request
Industrial Version	: IP66



Dimensions

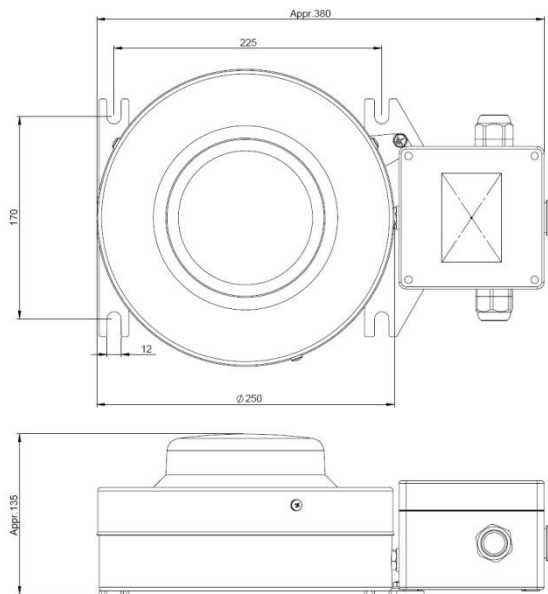

Ordering Details

Article code	Version	Voltage	Connection	Weight
ELRZ1AP0E443	IP66	24V	E012129 junction box 3 M20 entries with ECP	9Kg

* Earth Continuity Plate