

The IMT products are:

- Maintenance free
- Safety
- Environmental friendly

ILED®

Taurus Obstruction Low Intensity Group B

Main Characteristics

Approx 80,000 'maintenance free' operational hours.
Hermetically sealed for life
Shock and vibration resistant
Patented construction
According to CAA CAP437 and CAA CAP168

Specification/Technical Data

Housing	: Aluminium Heatsink and Stainless Steel 316L (AISI)
Lens	: Clear Borosilicate Glass
Ingress Protection	: IP66
Input Voltage	: 24Vdc ±10%
Input Current	: 1A
Light Source	: LED
LED Colour	: Red According tot ICAO
Light output	: 200cd. Steady burning according to CAA regulations (CAP437/ CAP168)
Burning Position	: Base Down
Ambient Temperature	: -40°to +40°C
Termination	: Standard -Junction Box c/w 3xM25 entries, Terminals suitable for max 10mm ² and communication max. 4mm ²

Certification details

ATEX Classification	: Group II, Category 2, Gas and Dust
Area Classification	: Category 2 (Zone 1 and 21)
Certificate (kema)	: KEMA 05ATEX2062
Marking	: ExII 2GD Ex e mb T4 T135°C



Dimensions

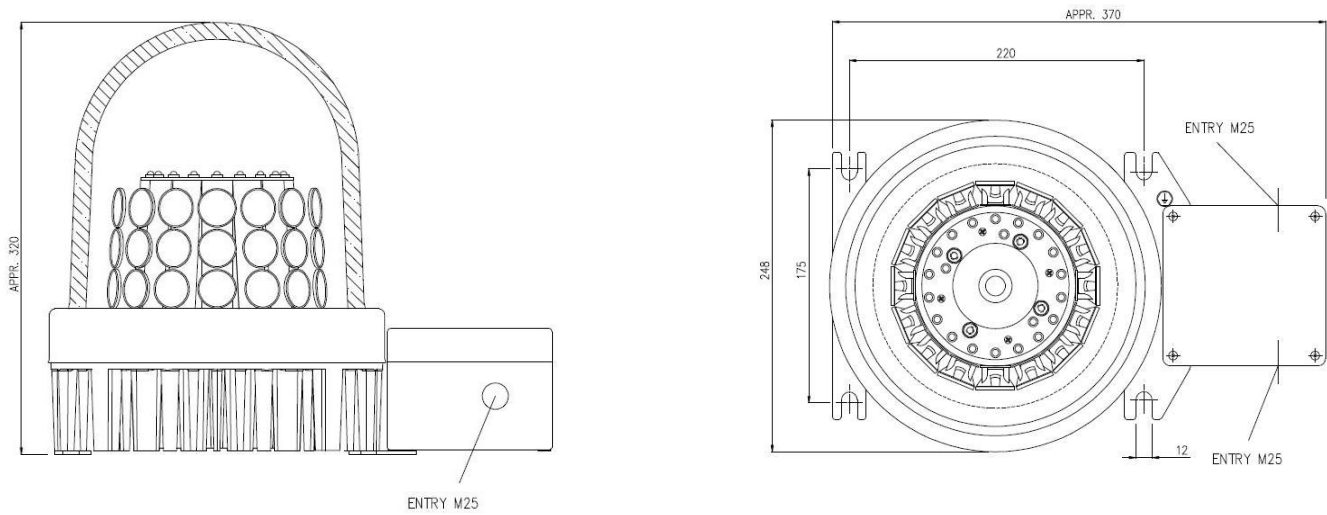

Ordering Details

Article code	Voltage	Connection	Weight